

Photon 100A Installation & Quick Start Guide

SaaS Version

This document describes how to get started using the Photon 100A with a SaaS DP. The SaaS DP is a cloud-based instance, hosted by Stellar Cyber for your use on a *.stellarcyber.cloud domain.

The steps are as follows:

- Connect power.
- Connect the Photon 100A to the network.
- Obtain an installation token from the Stellar Cyber GUI.
- Access the Photon 100A CLI.
- Change the management port settings.
- Apply the installation token in the CLI.

Connecting Power

To connect power to the appliance, have a licensed DC power technician:

1. Connect the included power cable to the DC power source.
2. Connect the cable to the Photon 100A.
3. Press the power button.

Connecting to the Network

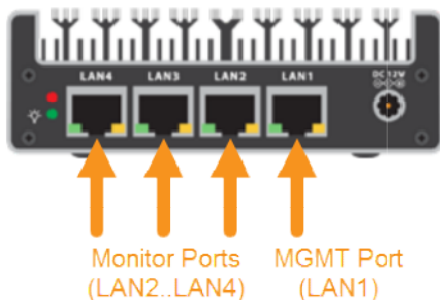

To connect the Photon 100A to the network:

1. Connect the management port (**LAN1**) to a network accessible by the DP.
2. Use the **LAN2..LAN4** monitor ports to connect to data sources (mirror ports or taps).

Obtaining an Installation Token

Stellar Cyber uses tokens to authorize and configure the installation of a sensor to be used with a SaaS DP. Tokens point the installed sensor to the correct DP, assign the specified tenant, and authorize the sensor installation.

Use the following procedure to obtain a token in the Stellar Cyber GUI:

1. Navigate to the **System | Deployment | Sensor Installation** page and click on the **Tokens** tab.
2. If a token already exists for the target tenant for the sensor installation, you can either use the **Copy** button to copy it to the clipboard or use the **Download** button to download it as a file.
 - Copy the token if you plan on applying it by pasting it into a `set token string <token>` command in the CLI.
 - Download the token as a file if you plan on hosting the file on an HTTP server and referring to it in a `set token url <token url>` command.
3. If there is not already an unexpired token for the target tenant, click the **Generate** button.
4. Select the tenant for the token from the **Tenant** dropdown. This is the tenant to which all sensors authorized with this token will be automatically assigned. The dropdown lists all tenants configured for your organization in the **System | Tenants** page.
5. Click the **Generate** button. The system generates the token and displays its contents in the **Token** field. The dialog also updates to display the expiration date for the token.
6. You can use the **Copy** button to copy the token to the clipboard immediately, or simply close the dialog and retrieve the token from the Tokens tab later on.

Accessing the Model 100A CLI

You can access the Model 100A by console or using SSH.

Console Access

For console access use:

- Baud: 115,200
- Flow control: none
- Data bit: 8
- Parity check: none
- Stop bit: 1

Note: If you are unable to connect at 115,200 baud, try 9,600 instead.

SSH Access

The default management IP address on the Photon 100A is **192.168.1.100/24**, and the default gateway IP address is: **192.168.1.1**. The default username is **abella** and the password is **changeme**.

For SSH access to the Photon 100A:

```
ssh -l aella@192.168.1.100
```

Power On and Log In

1. If the Photon 100 is not already powered on, press the power button on the left side of the front panel.
2. Update the administrator password. The default username and password are **aella** and **changeme**. You are prompted to change these when you first log in.

Change the Management Port Settings

1. You should still be logged in to your sensor from the previous procedure. If you are not, log in now using either SSH or a console connection with the credentials you set in the previous procedure.
2. You can set IP parameters manually using commands similar to the following (substitute your own IP parameters for the ones shown in bold below):
 - `set interface management ip 192.168.14.100/255.255.255.0`
 - `set interface management gateway 192.168.14.1`
 - `set interface management dns 8.8.8.8`
3. Verify the IP settings with the `show interfaces` command.

Applying the Token to the Sensor

Tokens are required to complete the installation of a sensor to be used with a SaaS DP.

1. Apply the token to the installed sensor from the sensor CLI with the `set token` command. The available techniques are as follows:
 - **Copy and Paste Token String** – Copy the token string from the **Tokens** tab and paste it into the CLI command. The syntax is as follows:

```
set token string <pasted string>
```
 - **Host Token on HTTP Server** – Download the token as a file from the **Tokens** tab, upload it to an HTTP server, and reference it in the `set token` command. The syntax is as follows:

```
set token url http://<url to token>
```
2. The CLI reports that the Sensor token is successfully set.
Note: If you receive an error message instead, it's possible that the token has expired. Refer to the **Tokens** tab to see the expiration date. If you are using the File technique, it's also possible that an extra space or line may have crept into your text file – check the file to make sure it includes only the token text.
3. Wait a minute or so. Then, verify that the token was successfully applied using any combination of the following techniques:
 - Check the **System | Sensors** tab in the user interface to see that the sensor has registered itself successfully.
 - Verify that the `show system` command shows all services as running.

- Verify that the `show receiver` command displays a receiver.
- Verify that the `show json` command reports some data sent in the `BYTE_SENT` column.